

Structural Relationship Between Coesite and Felspar

BY HELEN D. MEGAW

Crystallographic Laboratory, Cavendish Laboratory, Cambridge, England

(Received 14 May 1969)

Comparison of the structures of coesite and felspar shows (1) the usefulness of a model in which all O_4 tetrahedra are taken as perfectly regular and identical in size, the position and chemical nature of the central cation being ignored, (2) the possibility of order-of-magnitude correlation of lattice parameters with certain position parameters of O, by relating both geometrically to tilts of regular tetrahedra of the above kind, (3) evidence that the 'crankshaft' feature of the structure is not subject to a tensile stress in coesite, as it is in felspar, (4) an explanation why the felspar framework is not found in any polymorph of SiO_2 .

In their study of coesite, a high-pressure form of silica, Zoltai & Buerger (1959) noted a resemblance between its structure and that of felspar. The purpose of this paper is to examine the nature of the relationship. Only an outline of the geometry will be given here; a more detailed treatment will be given in another paper.

Fig. 1 shows half the structure of the potassium felspar, sanidine, (omitting K atoms) in projection on

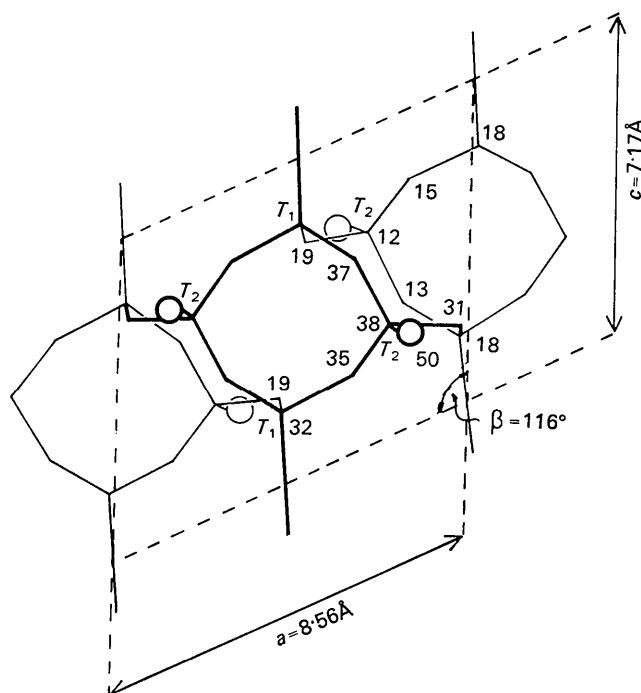

Fig. 1. 'Corrugated layer' of sanidine lying between heights $y=0$ and $y=\frac{1}{2}$. Heights of atoms are shown as multiples of $b/100$. $O_A(2)$ atoms are shown by circles; K atoms are omitted.

(010). The other half is derived by reflexion in mirror planes at $y=0, y=\frac{1}{2}$. If the structure could be cut in two at these planes, and each piece moved by $\frac{1}{2}c$ relative to the piece above or below, the arrangement shown in Fig. 2 would be obtained. Atoms $O_A(2)$ have been cut in half; those at height $y=0$ are shown, while those at height $y=\frac{1}{2}$ have been omitted for clarity. If now, by suitable tilting of tetrahedra without breaking any bonds, half atoms such as P and Q can be made to join up, the coesite structure will result. We note the existence of a centre of symmetry midway between P and Q .

Formally, the operation is simply one of replacing the mirror plane of the felspar by a c -glide plane, and moving $O_A(2)$ to a centre of symmetry lying on it, followed by minor adjustments of all the atomic position parameters. The 'corrugated layer', the part of the structure between heights 0 and $\frac{1}{2}$, is nearly the same in both structures, and has the same symmetry. It is shown schematically in Fig. 3.

The origin and axes of reference chosen by Zoltai & Buerger do not correspond to the conventional felspar axes. The latter are more convenient for general use. Both sets are shown in Fig. 3. Conversion from Zoltai & Buerger's axes to felspar axes is done with the following matrices:

$$\text{for lattice parameters, } \begin{pmatrix} 110 \\ 001 \\ 0\bar{1}0 \end{pmatrix};$$

$$\text{for atomic coordinates, } \begin{pmatrix} 100 \\ 001 \\ 1\bar{1}0 \end{pmatrix},$$

followed by a change of origin to $(\frac{1}{2}, 0, \frac{3}{4})$.

Data for coesite expressed on felspar axes are given in Table 1. The one-to-one correspondence between atoms is obvious. The felspar nomenclature will be used for them in what follows.

Table 1. Comparison of sanidine and coesite*

(a) Lattice parameters	Coesite (axes of Zoltai & Buerger)	Coesite (felspar axes)	Sanidine
<i>a</i>	7.17 Å	7.17 Å	8.56 Å
<i>b</i>	7.17	12.38	13.03
<i>c</i>	12.38	7.17	7.18
α	0	0	0
β	0	120.0°	116.0°
γ	120.0°	0	0

(b) Atomic position parameters

Coesite		Sanidine		
Axes of Zoltai & Buerger	Felspar axes			
0.5063		0.0063	0.0097	
0.5388	Si ₂	0.1576	0.1850	T ₁
0.1576		0.2175	0.2233	
0.1403		$\bar{1}$.6403	$\bar{1}$.7089	
0.0735	Si ₁	0.1084	0.1178	T ₂
0.1084		0.3168	0.3444	
0.5		0	0	
0.75	O ₂	0.1166	0.1472	O _{A(1)}
0.1166		0	0	
0		$\bar{1}$.5	$\bar{1}$.6347	
0	O ₁	0	0	O _{A(2)}
0		0.25	0.2858	
0.3080		$\bar{1}$.8080	$\bar{1}$.8278	
0.3293	O ₄	0.1030	0.1469	O _B
0.1030		0.2287	0.2244	

Table 1 (cont.)

		0.4877	$\bar{1}$.9877	0.0341	
		0.5274	0.2878	0.3100	O _C
	O ₅	0.2878	0.2103	0.2575	
		0.7306	0.2306	0.1792	
	O ₃	0.5595	0.1256	0.1269	O _D
		0.1256	0.4211	0.4025	

* Note added in proof:— These coordinates have been superseded by a new refinement by Arika & Zoltai (1969). The differences are however too small to affect the present argument, though significant in other respects. Araki & Zoltai have however chosen different axes of reference; these, and changes in Table 1 resulting from the new work, are recorded in the Appendix.

We now turn back to consider the character of the tilts which will allow *P* and *Q* in Fig. 2 to join up. We are really only concerned with the corners of tetrahedra, not with the positions of the Si or Al atoms within them. We make a simplifying assumption:

that, to a sufficiently good approximation, the tetrahedra (as defined by their O—O edges) are all regular, rigid, and identical in size.

We shall find that this provides a convenient working rule, whose validity can be tested by results. What we are really saying is that effects due to variation in tetrahedron size or shape are on the whole an order of magnitude smaller than those with which we are here concerned.

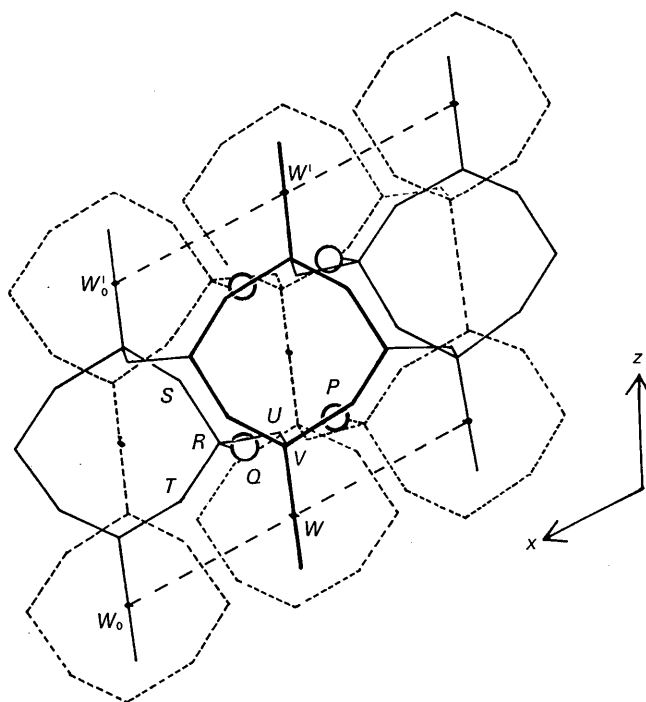

Fig. 2. 'Corrugated layer' of sanidine operated on by *c*-glide plane. Full lines: corrugated layer between $y=0$ and $y=\frac{1}{2}$ as in Fig. 1. Dotted lines: corrugated layer between $y=0$ and $y=-\frac{1}{2}$. Circles are O_{A(2)} atoms at $y=0$; other O_{A(2)}'s and some parts of the lower layer lying near the T₁'s in projection have been omitted for clarity.

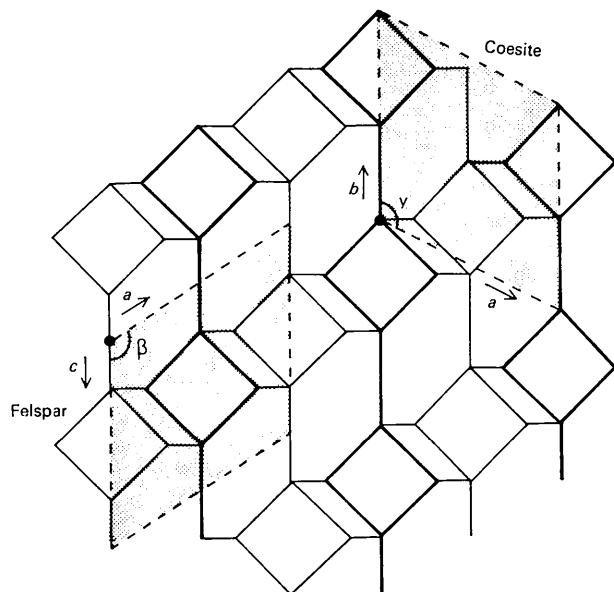

Fig. 3. Schematic diagram of 'corrugated layer' shown in Fig. 1, with lines joining centres of tetrahedra; oxygen atoms omitted. Squares with heavy lines are at heights near $y=0.35$, those with light lines near $y=0.15$. Unit cells are shown using the conventional felspar axes and the coesite axes of Zoltai & Buerger (1959), the third axis being vertically upward from the paper in both cases. For coesite, to obtain the axes of Araki & Zoltai (1969), the directions of a and b should be reversed (*i.e.* the origin taken at the top right-hand corner and b relabelled c).

Inspection of Fig. 2 shows that the tilt needed to make Q approach P is a hinging of tetrahedron $STUQ$ about its edge ST , which lies nearly in the direction $[001]$. (This is a tetrahedron of T_2 type, in felspar notation.) If it hinges so that R, U , and Q all come upward, the projected distance from ST to U shortens, while that to Q lengthens. Suppose all T_2 tetrahedra behave in a symmetry-related way, while the T_1 tetrahedra (such as that centred at V) remain fixed in orientation. Then the whole chain of four-rings running parallel to $[001]$, W_0W_0' , retains its unit of length and its orientation unaltered, but can move in any direction as required relative to a neighbouring chain, *e.g.* WW' . Shortening of the projected distance from the hinge to U serves to pull the two chains closer together in the x^* direction; lengthening of the projected distance to Q allows Q to approach the plane $x=\frac{1}{2}$, which is marked by the atom W , an $O_A(1)$ atom located in a special position on a diad axis. Because of the centre of symmetry, P and Q reach the plane $x=\frac{1}{2}$ together; minor adjustments (too small to consider at the present stage of discussion) bring them into coincidence on the plane.

The effects of this tilt on the overall dimensions of the unit cell can be calculated. Obviously there will be a decrease in $a \sin \beta$; we shall show that there is also a decrease in b , while c remains unaltered.

For calculating changes of tilt and of lattice parameters, we take a slightly simplified model, in which

each T_1 tetrahedron has its base exactly parallel to (010) with one edge perpendicular to (100) , and each T_2 tetrahedron has an edge such as ST exactly parallel to $[001]$. Part of this structure is shown in Fig. 4(a) and (b). In 4(a), it can be seen that the lattice vector $a/2$ is W_0W , which is the sum of projected vectors W_0N , NU , and UW . Of these, only NU changes with tilt. It gives rise to a change in $a \sin \beta$, while $a \cos \beta$ is unaffected. In Fig. 4(b), it can be seen that we are concerned with the horizontal component of NU . Similarly, a change in b is a change in the vertical component of QQ' [Fig. 4(b)], and this is equal to a change in the vertical component of $QU + N'Q'$, *i.e.* of NU , since UN' is unaltered and $N'Q'$ is, in magnitude and direction, the mirror image of NQ .

Assuming all tetrahedra have edge length 2.65 \AA , the slope of NU can be calculated from the experimental difference between the y parameter of U (O_C) and the mean of the y parameters of S and T (O_D and O_B). The angle between NU and the vertical is thus found to be 72° . From the geometry of the regular tetrahedron, the projected angles at N , U , and Q are $70, 55, 55^\circ$; hence UQ is at 17° to the vertical. Now in coesite the line UQ must be vertical (Fig. 5), since Q , like U , must be in the plane $x=\frac{1}{2}$; hence the angle of tilt needed to change

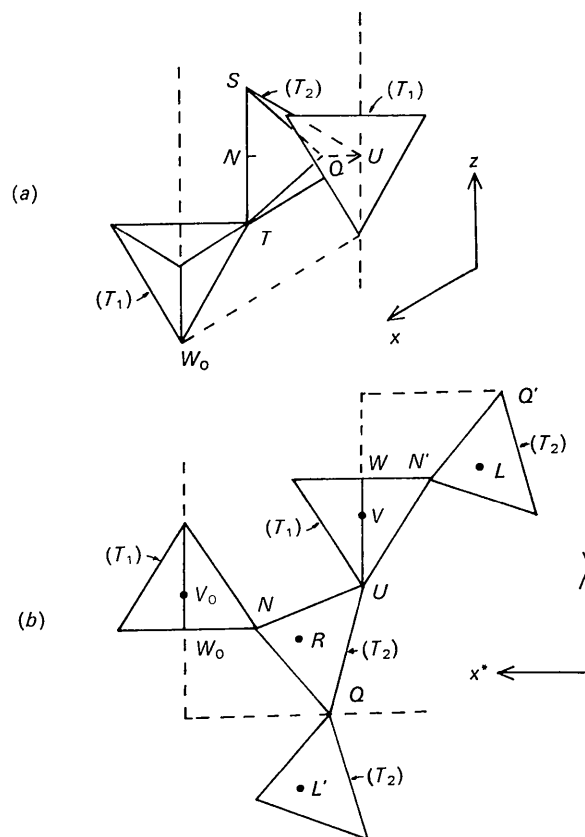

Fig. 4. Projections of parts of idealized felspar structure (a) on (010) , (b) normal to $[001]$. The lettering matches that of Fig. 2; centres of tetrahedra are marked in (b) but not in (a).

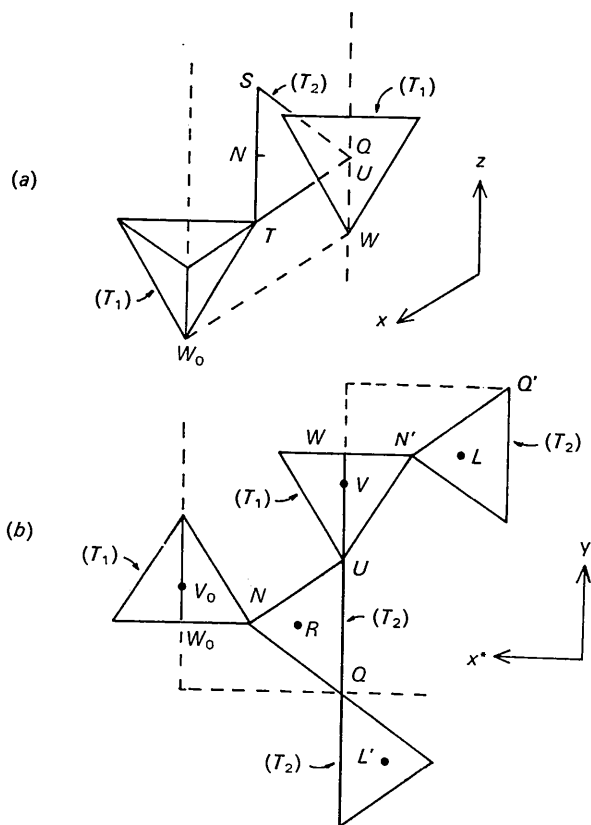

Fig. 5. Projections of parts of idealized structure, with tilt as for coesite; otherwise as Fig. 4.

from feldspar to coesite is 17° . (It is *not*, of course, suggested that this change actually occurs; we merely picture it as an aid to calculating differences between the actual end members.) From the relations in the last paragraph we predict a decrease in $a \sin \beta$ of 0.60 \AA and a decrease in b of 1.20 \AA ; also, since the change in $a \cos \beta$ is zero, an increase in β of 2° . The observed values are -1.5 \AA in $a \sin \beta$, -0.6 \AA in b , $+4^\circ$ in β . The predicted changes are thus of the right sign; order-of-magnitude agreement is reasonable considering the simplicity of the assumptions. The inclusion of other tilts might be expected to improve the agreement, but detailed treatment doing so will be left to another paper.

What has been done here is to show that a model involving only a simple change of tilt of tetrahedra can be correlated on the one hand with certain atomic parameters, on the other with lattice dimensions; and that errors implicit in the assumption of rigid regular tetrahedra, and errors arising from the neglect of other and more complicated tilts, are not so large as to destroy the possibility of making useful order-of-magnitude calculations. The tilts themselves have still to be explained, but this approach, by allowing each to be examined separately, offers more hope of explaining

the nature of the differences between structures. In this paper we consider only the tilt discussed above.

The task is to try and explain the differences between the frameworks of sanidine and coesite, correlating them with the presence or absence of the large cation K. We begin by recognizing that differences between individual tetrahedra containing Si or Al are negligible, and that even for the structure as a whole the effect of Si/Al replacement means only a difference of about 2% in the average O-O edge length, and this too can be neglected.

We have now shown that the main differences in the coesite and sanidine frameworks are due to two features: (1) there is a different linkage between corrugated layers through $O_A(2)$, such that two $T_2-O_A(2)$ bonds are related in sanidine by a mirror plane, in coesite by a symmetry centre; (2) tetrahedra T_2 have different tilts in the two structures. We proceed to examine the implications of (2).

Consider the characteristic 'crankshafts' of the feldspars - strips running parallel to $[100]$ and made up of horizontal four-rings joined to vertical four-rings, as shown schematically in Fig. 6. ('Vertical' is here ta-

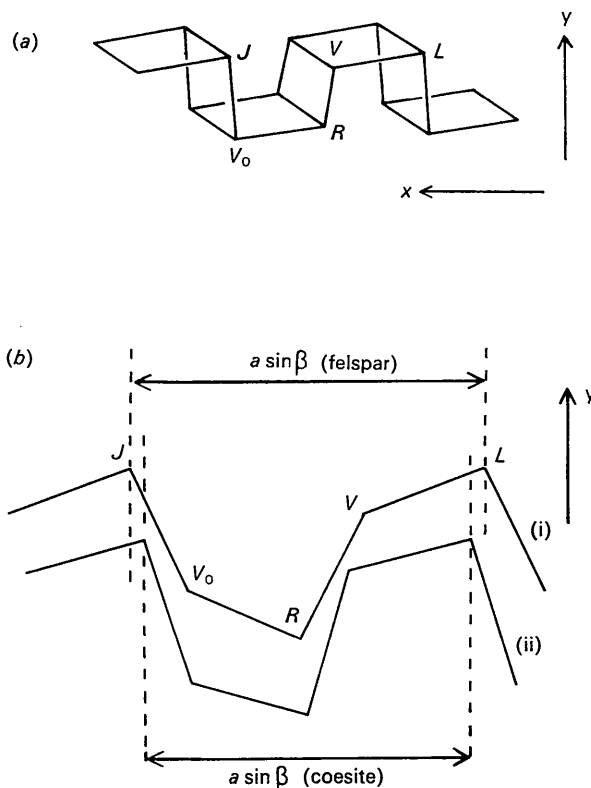

Fig. 6. 'Crankshaft' part of structure. Lines show joins between tetrahedral atoms, oxygen atoms being omitted (*cf.* Fig. 2). (a) Perspective view, schematic. (Actual four-rings are not planar, nor are their sides exactly parallel to the axes.) (b) Projection perpendicular to $[001]$: (i) for feldspar, (ii) for coesite [corresponding to Figs. 4(b) and 5(b) respectively]. The same lettering is used for the same atoms throughout.

ken to mean 'parallel to [010]', and 'horizontal' to mean 'in the (010) plane.') It is plain that the greater the tilt of the T_2 tetrahedron from its coesite position, the greater the inclination to the vertical of the links such as RV and JV . Tilting of the tetrahedra thus implies a lengthwise pulling-out of the crankshaft strips. (There is a shear as well as an extension, because the strips are parallel to [100] whereas the effects of tilt are in the plane normal to [001], but we need not consider that here.)

Now it has been shown (Megaw, Kempster & Radoslovich, 1962; Fleet, Chandrasekhar & Megaw, 1966) that the crankshaft strip is, in all feldspars, under a tensile stress, whose source is in the pair of large cations, in this case K atoms, jammed in so that they lie in a line between two $O_A(2)$'s. The electrostatic repulsion between the two K's produces a thrust in the $O_A(2)$ -K-K- $O_A(2)$ 'strut', which is balanced by the tension in the crankshaft 'tie'. This was verified by detailed examination of the bond-angle strains in the crankshaft (*i.e.* the deviations from a tetrahedral bond-angle) for all feldspars for which data were available; irrespective of differences of symmetry or composition, they were all found to be of the sense corresponding to a tensile stress in the crankshaft. It is therefore no surprise to find that in coesite, where there are no cation 'struts' to hold the crankshaft extended, it contracts to an unstrained length. Fig. 6(b) compares the actual shape of the crankshaft (the joints not included in the diagram being related to those that are by symmetry). JV_0 and RV lie in the plane of projection. The more pulled-out configuration in feldspar is easily seen.

From this discussion it can be seen why the two materials $KAlSi_3O_8$ and SiO_2 adopt the two different structures. Obviously the coesite structure is impossible for $KAlSi_3O_8$, because there are no cavities in it of suitable size for K. At first sight, however, there appears no reason why SiO_2 should not occur with the feldspar structure. Closer examination shows the difficulties. If the T_2 tetrahedra retained the coesite tilt of approximately zero, while being related across a mirror plane, the bond angle at $O_A(2)$ would be 110° , which empirical evidence suggests is too small for stability. In feldspars, this difficulty is avoided by introducing T_2 tilts, at the cost of introducing also tensile stress in the crankshaft; for SiO_2 this remedy is impossible, because of the lack of compensating cation struts. In feldspars, the linkage of corrugated layers across a mirror plane through $O_A(2)$ not only provides cavities of sufficient size for the cations but also allows their mutual electrostatic repulsion to be counterbalanced by the elastic tensions of the layers, applied to them through $O_A(2)$. In SiO_2 there are neither cations requiring large cavities nor electrostatic repulsions by which a stress can be applied to the layers to tilt the T_2 octahedra, and therefore there is neither the demand nor the opportunity for mirror symmetry at $O_A(2)$.

This discussion has not yet mentioned the very unusual feature of the coesite structure which results

from centrosymmetry at $O_A(2)$, namely the straight-line configuration of T_2 - $O_A(2)$ - T_2 . From the work of Liebau and others (see Liebau, 1961) it is now generally recognized that straight-through links are not energetically favourable, and occur less often than the older work on silicates would have suggested, though their existence has been confirmed in some structures [*e.g.* in thortveitite Sc_2SiO_7 (Cruickshank, Linton & Barclay, 1962)]. In coesite, it may be favoured by the high-pressure conditions under which the structure is formed. From our present point of view, it can only be said that a normally unstable arrangement in the inter-layer link at $O_A(2)$ is the price the coesite structure has to pay for what our discussion suggests to be a favourable, unstrained, condition within the layers.

More detailed discussion of the geometry of the structures, with an analysis of the different kinds of possible tilts and their effects, and comparisons of different feldspars, will be left to later papers.

APPENDIX

For their new refinement, Araki & Zoltai (1969) have used axes of reference derived from those of Zoltai & Buerger (1959) by the matrix $\bar{1}00/001/0\bar{1}0$; and some, but not all, of the prototype atoms (representative atoms of each equipoint) are differently chosen. Table 2 gives the refined atomic parameters for the same prototype atoms as Table 1, (a) referred to Araki & Zoltai's 1969 axes, (b) referred to the feldspar axes of Fig. 3. (Other parts of Table 1 remain unchanged.)

Table 2. Atomic position parameters of coesite referred to (a) Araki & Zoltai's axes, (b) feldspar axes

(a)		(b)		(a)		(b)
0.4934		0.0066		0.6891		T-8109
0.1577	Si ₂	0.1577		0.1036	O ₄	0.1036
0.4596		0.2162		0.6755		0.2364
0.3590		T-6410		0.5193		T-9807
0.1084	Si ₁	0.1084		0.2882	O ₅	0.2882
0.9274		0.3184		0.4788		0.2095
1/2		0		0.2670		0.2330
0.1172	O ₂	0.1172		0.1238	O ₃	0.1238
1/4		0		0.4418		0.4248

References

- ARAKI, T. & ZOLTAI, T. (1969). *Z. Kristallogr.* **129**, 381.
 CRUICKSHANK, D. W. J., LYNTON, H. & BARCLAY, G. A. (1962). *Acta Cryst.* **15**, 491.
 FLEET, S. G., CHANDRASEKHAR, S. & MEGAW, H. D. (1966). *Acta Cryst.* **21**, 782.
 LIEBAU, F. (1961). *Acta Cryst.* **14**, 1103.
 MEGAW, H. D., KEMPSTER, C. J. E. & RADOSLOVICH, E. W. (1962). *Acta Cryst.* **15**, 1017.
 ZOLTAI, T. & BUERGER, M. J. (1959). *Z. Kristallogr.* **111**, 129.